

Description	Type	Page
System overview	OptoLink	102
OptoLink 800		
Optical transmitter	OT(M)	103
Optical receiver, downstream	OR	104
Optical receiver, upstream	OR(M)	105
Optical Mini Node	ONB	106-107
OptoLink 2000		
Optical compact transmitter	LTO	108
Optical compact receiver	LRO	109
Opto accessories		
Optical compact splitters	LSO	110
Optical attenuators	OA	110



OPTICAL SYSTEMS

OptoLink – the optical transmission system for analogue and digital TV signals from DCT-DELTA

Modern optical transmission systems (fibre optic cable) are best suited when TV signals (AM-TV, QAM, QPSK, FM) with RF carriers need to be transmitted over longer distances. The high band widths of analogue or quasi analogue modulated signals make extremely high demands on network components:

- Highly linear electric-optical converters in form of cooled DFB lasers with a pre-distortion board
- Exclusive use of mono-mode optical fibres
- Exclusive use of optical connectors of type APC with 8° angle polished contact areas

The DELTA OptoLink products are tailored for two application segments:

1. **OptoLink 800** for HFC networks from 5-862 MHz with preferably AM modulated (analogue) and QAM modulated (digital) TV signals
2. **OptoLink 2000** for SAT-IF feeder lines or combined super broadband networks with the frequency range of 47-2400 MHz

Product overview *OptoLink*

Description	OptoLink 800	OptoLink 2000
Preferred application	BK / CATV	SAT-IF (+CATV)
Frequency range	5 ... 862 MHz	47 ... 2400 MHz
19" housing	Optical transmitter 1310 nm	OT(M) 813
	Optical receiver, downstream	OR 801
	Optical receiver, upstream	OR(M) 203
Die-cast housing	Optical compact transmitter 1310 nm	–
	Optical compact receiver, downstream (Node)	ONB 800 (R)
	with built-in return path transmitter 1310 nm	ONB 800 (R) - FP 1310
	with built-in return path transmitter 1550 nm	ONB 800 (R) - DFB 1550
Optical compact receiver, upstream (Node)	–	LRO 1300 S (T)

HFC network with *OptoLink 800*

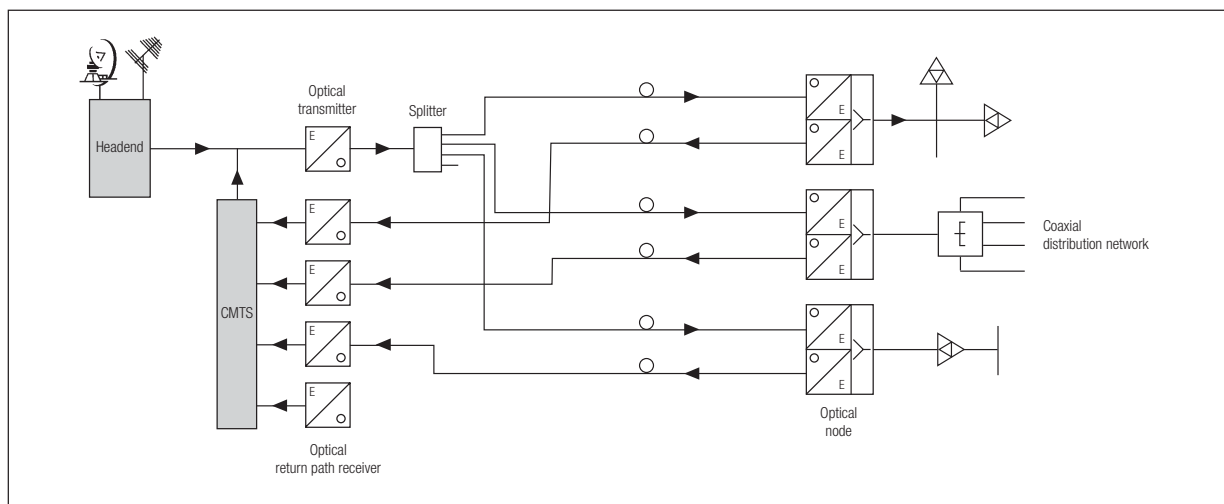

OPTOLINK 800

Optical transmitter – base unit

- 19" Base unit 1 RU with control unit and power supply and 2 slots for transmitter modules OTM 813-xx
- Flexible and service-friendly through modular construction, module slot on rear chassis
- User friendly and clean setup: signal connectors on rear chassis, displays and test points on front chassis
- Microprocessor controlled and display functions with alpha-numeric LCD display
- Addressable network management interface for remote control of modules and base unit
- Alarm signalization in case of fall-out with LED's



Type	OT 813	
Article No.	5700 1321	
Plug-in slots for transmitter modules	2	
NMS-Interface	RS 232/485	
Operating temperature	°C	+ 5 ... + 40
Testpoints	2 x F female	
Operating voltage	V~	230 (86 - 264)
Power consumption	W	50 (Base unit complete with 2 transmitter modules)
Dimensions	mm	19" 1 HE

Transmitter modules for OT 813

- Transparent conversion of electrical signals (AM-TV, QAM, FM) to amplitude modulated optical fiber signals
- 1310 nm DFB laser, cooled, with electronic multi-point-predistortion - keeps intermodulation interference (CTB, CSO) low
- μ P-controlled level control (ALC) for uncomplicated electric operation with constant transmission parameters



Type	OTM 813-08	OTM 813-10	OTM 813-12	OTM 813-13.5	
Article No.	5700 1322	5700 1323	5700 1324	5700 1325	
Optical output power	dBm	8 (6 mW)	10 (10 mW)	12 (16 mW)	13,5 (22 mW)
Laser type	direct modulated DFB laser, cooled				
Optical wavelength	nm	1310 \pm 20			
RF frequency range	MHz	47 - 870			
RF input level	dB μ V	80 \pm 3 (multiple channel load > 20 AM/TV channels)			
CNR		52 (10 Km fiber distance, receiver input 0 dBm)			
CTBR / CSOR	dB	67 / 62			
RF flatness	dB	\pm 0,75			
Return loss	dB	> 16 / 47-550 MHz, > 14 / 550-870 MHz			
Operating temperature	°C	+ 5 ... + 40			
Fiber connector		SC/APC (FC/APC on request)			
RF connector		F female			

OPTOLINK 800



Optical receiver, downstream

- Transparent converter of intensity modulated optical fiber signals to electrical signals
- Preferable for mixed multi-channel allocation with AM-TV-QAM- and FM-channel packets
- Recommended as optical forward path receiver for fiber optical trunks in HFC hubs
- Service-friendliness through modular construction, consisting of base unit with power supply and receiver slot
- User friendly and clean setup: signal connectors on rear chassis, display and test points on front chassis
- DC test point, optical input level (5 V/mw) and level signalization with LED

Type		OR 801
Article No.		5700 1328
Optical wavelength	nm	1000 - 1600
Optical return loss	dB	> 45
Optical input level	dBm	-6 ... +3
RF frequency range	MHz	47 - 862
RF output level	dBμV	103 (@ 0 dBm optical input power, OMI = 4%)
CNR	dB	51 (@ 0 dBm optical input power, OMI = 4%)
CTBR	dB	65
CSOR	dB	62
Testpoint optical input	V/mV	5
Testpoint RF output	dB	-20
Operating temperature	°C	+ 5 ... + 40
Fiber connector		SC/APC (FC/APC on request)
RF connector		F female
Operating voltage	V~	180-244
Power consumption	W	20 (unit complete with receiver module)
Dimensions	mm	19" 1 HE

Clearly laid out and user-friendly

- Optical-electrical converter module with low noise pre-amplifier
- High output level with low, non-linear distortions (CTB, CSO) through power doubling output stage
- Connections for fiber (SC/APC) und RF socket for signal output on rear chassis
- Contacting of display and test signals via SUB-D rails to front panel of base unit



■ OR 801 rear view

OPTOLINK 800

Optical receiver, upstream – base unit

- Modular optical return path receiver for fibre optical hubs in HFC and FTTx access networks
- Configurable for point-to-point and point-to-multipoint connections
- 19" 1RU base unit with plug-in slots for up to 3 receiver modules ORM 200
- Flexible and service-friendly through modular construction, module slot on back of unit
- User friendly and clean setup: signal connections of backside, displays and test points on front panel
- For each module slot: Test point optical input level and level signalization with LED, as well as test point of RF output level



Type	OR 203	
Article No.	5700 1326	
Plug-in slots for receiver modules	3	
Operating temperature	°C	+ 5 ... + 40
Connector testpoint	F female	
Operating voltage	V~	230 (180-244)
Power consumption	W	46 (base unit complete with 3 receiver modules)
Dimensions	mm	19" 1 HE

Receiver module for OR 203

- Opto-electrical converter with low noise pre-amplifier
- High drivability through power doubled final stage. Prevents compression of digital return path packets, i.e. no or very little degredation of bit error rate or of MER
- Plug-in coupler for fibre optic cable (SC/APC) and RF socket for signal output on back panel
- Contacting of display and test signals via SUB-D rail for front panel of base unit



Type	ORM 200	
Article No.	5700 1327	
Optical wavelength	nm	1000 - 1600
Optical return loss	dB	> 45
Optical input level	dBm	-6 ... +3
RF frequency range	MHz	5 - 200
RF output level	dBµV	100 (@ 0 dBm optical input power, OMI = 4%)
CNR	dB	51 (@ 0 dBm optical input power, OMI = 4%)
CTBR	dB	65
CSOR	dB	62
Testpoint optical input	V/mV	5
Fiber connector	SC/APC (FC/APC on request)	
RF connector	F female	

OPTOLINK 800



Mini Fibre Node

- Optical compact receiver with built-in optical return path transmitter
- Compact die-cast housing, IP 50
- High output level and dynamic range
- Plug-in slot for AGC module (AGC 203, see page 43) for automatic gain control to compensate level variations due temperature shift
- Flexible return path solution, with plug-in modules (RLK 30, RLK 65, see page 41) for 5-30 / 5-65 MHz selectable
- Level settings: RF output level and RF return path input level with pads (PAD xx L, see page 44) in 1 dB steps adjustable
- LED indication for transmitter and receiver status
- Test points -20 dB at input and output
- Highly efficient switch mode power supply
- For local or remote feeding

Type		ONB 800	ONB 800 R			
Downstream Receiver	Article No.	5700 0913	5700 0916			
	Operating voltage	V~	185-65	30 - 65		
	Remote current max	—	0,5 A @ 30 VAC			
	Optical connector	SC/APC				
	Optical wavelength	nm	1310 (1290 ... 1600)			
	Optical input level	dBm	- 6 ... + 2			
	Frequency range	MHz	47-862 / 85-862 (depends on used diplexer)			
	Linearity	dB	± 0,7			
	Output level (gain limited)	dBμV	113 @ 0 dBm, OMI 4%			
	Max. RF operation level	dBμV	106 @ 0 dBm, OMI 4%, CTBR/CSOR > 60 dB, 42 Ch.			
	CTBR/CSOR	dBc	70/65 @ -3 ... 0 dBm, OMI 4%, U _{OUT} = 98 dBμV, 42 Ch.			
	CNR	dB	> 53 @ -3 dBm, OMI 4%			
	AGC range (option)	dBμV	-3 ... 0 @ 106 dBμV, ATT 0 dB -6 ... 0 @ 100 dBμV, ATT 0 dB			
	Equalization / pre-emphasis	dB	0 ... 20 (with pads in 1 dB steps adjustable)			
Attenuation	dB	0 ... 20 (with pads in 1 dB steps adjustable)				
Power consumption	W	13,5				
RF-Connector		1 x F female				
Dimensions	mm	210 x 123 x 70				
Weight	kg	1,3				
Upstream Transmitter		ONB 800 - FP 1310	ONB 800 - DFB 1550*	ONB 800 R - FP 1310	ONB 800 R - DFB 1550*	
	Article No.	5700 0914	5700 0915	5700 0917	5700 918	
	Laser type *	1310 nm FP	1550 nm DFB	1310 nm FP	1550 nm DFB	
	Optical output	dB	0	+3	0	+3
	Diplexer frequency range	MHz	5-30 MHz (diplexer RLK 30) / 5-65 MHz (diplexer RLK 65)			
	Return path bandwidth	MHz	5-200 MHz (via separate return path input)			
	RF input level	dBμV	OMI 40%: 83 dBμV, OMI 5%: 65 dBμV (with Pads in 1 dB steps adjustable)			
Attenuation	dB	0 ... 20 (with Pads in 1 dB steps adjustable)				

* CWDM (1471 - 1611 nm) on request

OPTOLINK 800

Optical Mini Node ONB 800 (R)

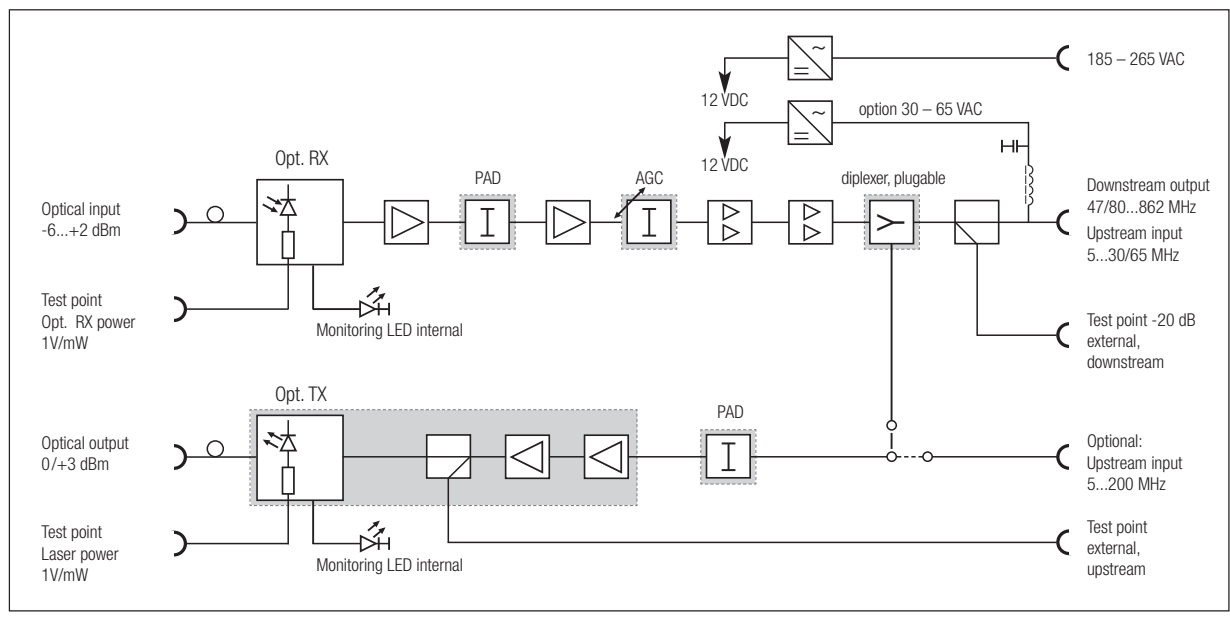

plug-in slot for optional modules

Applications of Mini Node

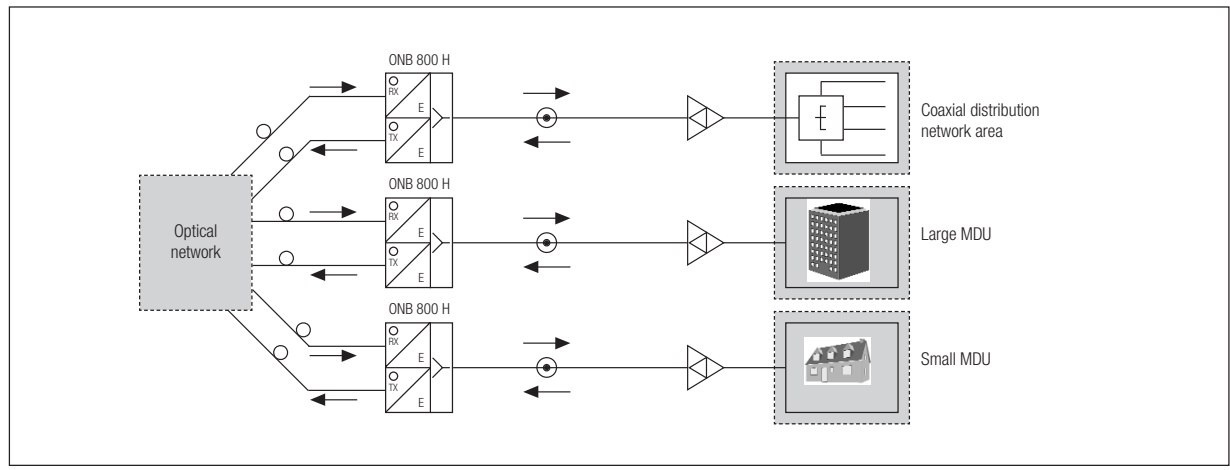

OPTOLINK 2000



Optical compact transmitter

- Frequency range 47-2400 MHz
- Optical wavelength 1310 nm
- Useful for transmitting of terrestrial and SAT-IF signals
- Compact die-cast housing, IP 50
- Laser type: DFB-Laser

Type		LTO 1306 S
Article No.		1016 1382
Optical wavelength	nm	1310 ± 10
RF connector input		F female
Input impedance	Ω	75
Frequency range	MHz	47 - 2400
Input level		
CTBR/CSOR > 60 dB/42 Ch.	dBμV	87 ... 94
Return loss	dB	> 14
Optical connector output		FC/APC
Optical output power	dBm	6
Return loss output	dB	> 55
Linearity	dB	± 0,5
Operating voltage	V~	230
Power consumption	W	3
Operating temperature	°C	+ 5 ... + 50
Dimensions	mm	225 x 190 x 86
Weight	kg	2

OPTOLINK 2000

Optical compact receiver

- Optical wavelength 1310 nm
- Useful for transmitting of terrestrial and SAT-IF signals
- **LRO 1300 T:** Receiver 47-862 MHz
- **LRO 1300 S:** Broadband receiver 47-2400 MHz
- Excellent linearity
- Compact die-cast housing, IP 50





Type		LRO 1300 T	LRO 1300 S
Article No.		1016 1632	1016 1383
Optical wavelength	nm	1310 ± 10	1310 ± 10
Optical connector input		FC/APC	FC/APC
Optical input power	dBm	2	2
Optical return loss	dB	> 55	> 55
C/N	dB	> 50	> 50
RF connector output		F female	F female
Frequency range	MHz	47 - 862	47 - 2400
Impedance	Ω	75	75
Linearity	dB	± 0,5	± 0,5
Output level		at 0 dBm optical input power	
CTBR/CSOR > 60 dB/42 Ch.	dBμV	94	94
Return loss	dB	> 14	> 14
Operating voltage	V~	230	230
Power consumption	W	6	6
Operating temperature	°C	+ 5 ... + 50	+ 5 ... + 50
Dimensions	mm	225 x 190 x 86	225 x 190 x 86
Weight	kg	2	2

OPTO ACCESSORIES



Optical compact splitters

- Optical 2-way and 4-way splitter
- Optical wavelength 1310 nm
- Useful for transmitting of terrestrial and SAT-IF signals
- Compact die-cast housing, IP 50

Type		LSO 1300-2	LSO 1300-4
Article No.		5700 0629	5700 0630
			
Optical outputs		2	4
Optical connector		FC/APC	FC/APC
Optical wavelength	nm	1310 ± 40	1310 ± 40
Attenuation	dB	3,7 ± 0,3	7,4 ± 0,3
Optical return loss	dB	> 55	> 55
Isolation	dB	> 55	> 55
Operating temperature	°C	+ 5 ... + 50	+ 5 ... + 50
Dimensions	mm	225 x 190 x 86	225 x 190 x 86
Weight	kg	1,7	1,7

Optical attenuators

- Metal ion de-oxidized fibre glass
- Premium performance for CATV applications
- Dual wave length capability 1310 nm / 1550 nm
- APC contact areas with 8° angle polish for mono-mode fibre glass
- Other attenuator values available on request

Type		OATN 03FC	OATN 06FC	OATN 10FC
Article No.		5700 0907	5700 0908	5700 0909
Optical connector	nm	FC/APC	FC/APC	FC/APC
Attenuation	dB	3	6	10

Type		OATN 03SC	OATN 06SC	OATN 10SC
Article No.		5700 0910	5700 0911	5700 0912
Optical connector	nm	SC/APC	SC/APC	SC/APC
Attenuation	dB	3	6	10